

HAZARD ALERT LIVE TOMORROW

ELECTROCUTION

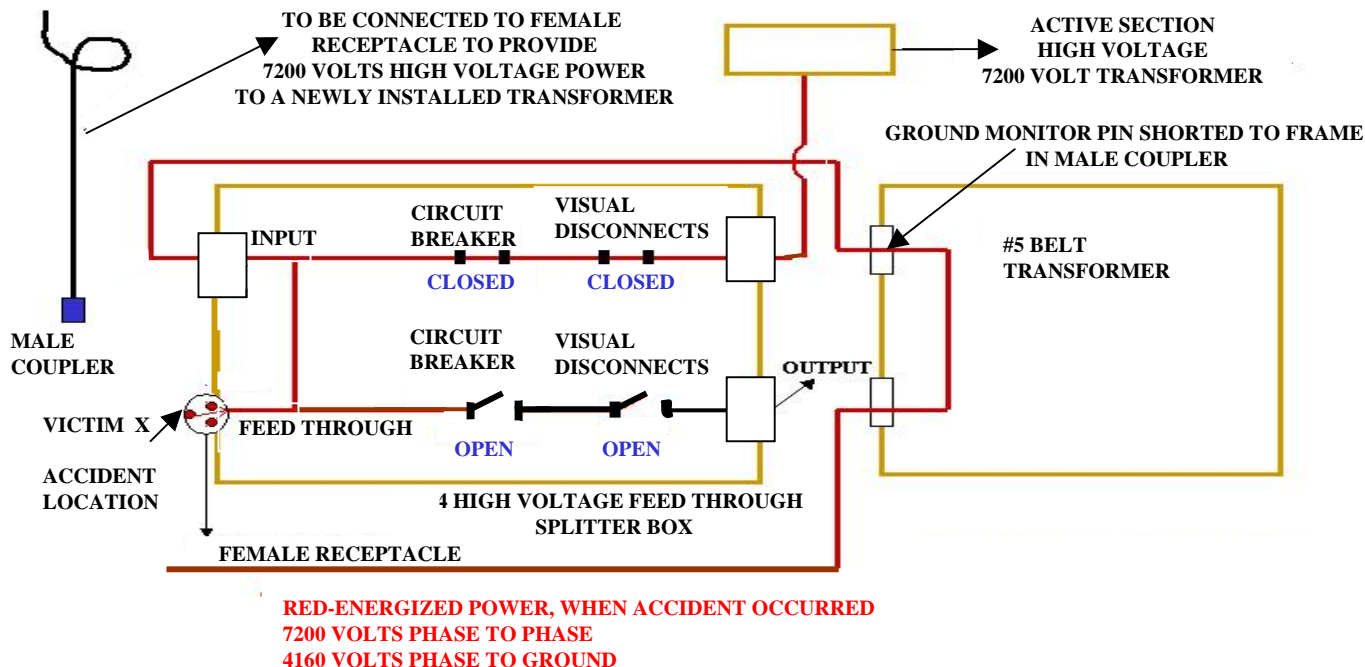

On September 24, 2004, a face equipment operator, was electrocuted when he came in contact with an energized high voltage phase terminal in a female receptacle on a feed through splitter box. The victim and a coworker (repairman) were cleaning and preparing the male coupler and female receptacle that would be connected and put into service on the next shift. The female receptacle terminals were energized with 7200 volts, phase to phase, and were connected directly to the feed through circuit. The repairman opened the visual disconnects while thinking that he was deenergizing the power to the female receptacle.

SAFETY KEYPOINTS:

- No electrical work shall be performed on low, medium, or high voltage distribution circuits or equipment, except by a certified person or by a person trained to perform electrical work and to maintain electrical equipment under the direct supervision of a certified person.
- Ensure the correct disconnecting device(s) is locked out and suitably tagged by the persons who perform electrical or mechanical work on such circuits or equipment connected to the circuits.
- All high-voltage circuits shall be grounded before repair work is performed. The certified electrical repairman shall effectively ground the high voltage circuit prior to performing any work on the deenergized circuit.
- Be familiar with any high voltage unit containing a feed thru circuit; observe and understand the safety precautions and labeling displayed on the unit.
- Remember!! If it's not grounded, then it's not safe to work.

Please Post "2004"

For additional information or assistance, contact the Division of Mines, Big Stone Gap (276) 523-8227 or Keen Mountain Office (276) 498-4533

ACCIDENT
REDUCTION PROGRAM

